

INTRODUCTION

Please read the entire users guide before using the hub. For the newest version of this guide or for miscellaneous questions, please consult the official representative for the country in which you reside or consult our website www.last-bikes.com.

CAUTION - In the case of non-compliance with these instructions, the function of the product will be impaired, which may lead to injuries with serious consequences, and the loss of the product guarantee.

INTENTIONAL USE

Last hubs are designed to be used on bicycles only. They are not designed for the bicycle discipline trial nor for use on a tandem nor for single speed cross country riding.

IMPORTANT

- Before every use, check the function of your rear wheel hub. Make sure that the freewheel and engagement connection function impeccably. Should there be any mal-function, the rear wheel hub must not be used. In such a case, the problem must be repaired before use. If you are not in a position to repair the hub, contact a professional bike mechanic.
- New hubs have a higher rolling resistance than used hubs, because the grease in the freewheel has not yet been evenly distributed and the seals have not yet been bedded in.
- **CAUTION** - Radial lacing on our hubs is not recommended as it may lead to impermissible deformations on the hub

flange. Flange breakage is not covered under the warranty in this case. Spokes must cross 3 times.

- Disregarding these instructions will limit the function of the freewheel and can lead to injury or other severe consequences and the loss of the product warranty.
- **CAUTION** - Do not use shorter axle bolts. Use bolts with at least 800 N/mm² tensile strength. Tighten bolts to max. 35 Nm. Do not over tighten the bolts to prevent wheel slippage, use chain tensioners instead. Over tightening will harm the structure of the hub.
- **CAUTION** - The chainline of the hub is 50 mm. Adjust your sprocket accordingly, so the chain runs straight. Otherwise the driver will show excessive wear on the teeth.
- **CAUTION** - Chains lengthen after months of use. This leads to load concentration on a single tooth of the driver. Change our chain before it is worn out to protect the teeth of your driver.
- Do not use high pressure water jets to clean the hubs.
- Maintenance work and repairs must be carried out by professional bike mechanics or similar qualified persons using the available special tools. For Maintenance work and repair instructions refer to the technical manual which can be downloaded from our website www.last-bikes.com.

MAINTENANCE OF THE HUBS

Maintenance of the rear and front hub must be carried out at least once a year. When used under extreme conditions (heavy rain, mud, transport in the rain etc.) the free-wheel should be serviced more often. Regular maintenance of the hub helps to ensure a longer life and optimum running per-

formance for years. In the case of exposure to water under excessive pressure (e.g. high-pressure cleaners), water may penetrate into the hub. This may damage the hub. Do not use any solvents or detergents.

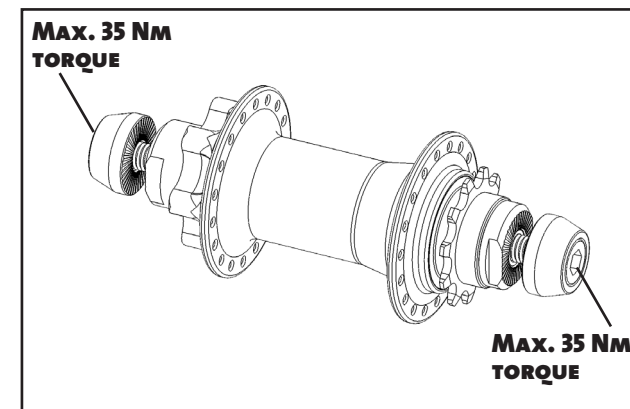

WHEEL BUILDING INFORMATION

| | |
|-----------------------------------|---------|
| spoke hole pattern diameter (PCD) | 58,0 mm |
| spoke hole diameter | 2,5 mm |
| distance flange to center line | 35,5 mm |
| symmetrical (left = right) | |

WARRANTY TERMS

Please visit our website for the latest version of the warranty terms.