

Specification // HERB 180 2012 - complete bike

| | |
|--------------------------|---|
| frame | HERB 180 V1.1 incl. Monarch Plus RC3 HV shock, black anodized |
| sizes | small, medium, large |
| fork | Rock Shox Lyrik, RC, Solo Air, 170 mm |
| head set | Acros AiSXE-22, stainless steel bearings, red |
| stem | Truvativ AKA, 60 mm, 5° |
| handle bar | Truvativ Boobar, 740 mm wide, 20 mm rise |
| brakes | Avid Code R, 200 mm front rotor, 180 mm rear rotor |
| front derailleur | Shimano XT FDM-970-10 |
| derailleur | Sram X9, 10 speed, black/red |
| shifter | Sram X9 Trigger, 10 speed |
| cassette | Sram PC-1050, 10 speed, 11-32T |
| crank and bottom bracket | SRAM Truvativ X9 with bash guard, 22T, 36T |
| chain device | NC-17 Stinger |
| wheel set | DT Swiss E2000, front 20/110 mm, rear 12/135 mm, black |
| tires | Schwalbe Muddy Marry, 2,35", foldable, front soft, rear medium compound |
| seat post | Truvativ Stylo T30, 31,6 x 420 mm, 7050 Al |
| optional seat post | Rock Shox Reverb, 125 mm adjustable, 31,6 x 420 mm |
| seat | Selle Italia SL XC, black |
| seat clamp | Syntax Super Lock |
| pedals | not included |

Helpful Information

The HERB 180 complete bike is build around our original HERB 180 aftermarket frame using only parts of exceptional quality.

This year we use the new X9 cranks, which supply you with a 2x10 speed drive train fitted with a 36 and 22T sprocket up front and bash guard.

Finally we put the bike on black DT Swiss EX 2000 wheels, wich come with stiff through axles up front and rear and feature the unique star ratchet free wheel system. On the rims you find Schwalbe Muddy Marry 2,35" tires - medium compound on the rear and soft up front.

The information given in this document is subject to change without notice.

Specification // HERB 180

| | |
|--------------------------|--|
| version | HERB 180 (V1.1) |
| sizes | small, medium, large |
| colours | black anodized frame, red anodized linkage and hardware |
| material | 7005 aluminum, custom butted, heat treated and ball burnished (less fatigue) |
| rear travel | 180 mm (can be changed to 160 mm with HERB 160 rockers, use same shock length) |
| standard shock | Rock Shox Monarch Plus RT3 High Volume, 216 x 63,5 mm |
| shock hardware | 8 mm bolt, top 47,8 mm width, bottom 22,2 mm width |
| seat post and clamp size | ∅ 31,6 mm, 100 mm min. insertion, clamp ∅ 34,9 mm, not included |
| bearings | stainless steel sealed cartridge bearings |
| bearing sizes | 15 x 28 x 7 mm |
| head tube | tapered, bottom 1,5" 1 1/8" internally and externally CNC machined |
| head sets | bottom - semi integrated 1,5" (55,96-56,00 mm), top 1 1/8" semi integrated (44 mm) |
| compatible tires | 26" x 2,7" |
| disc mount | Internat. Standard, max. ∅ 205 mm |
| bb shell | BSA, 73mm, 83 mm bottom bracket with 5 mm spacers on each side |
| front derailleur | Shimano top swing only, for example FDM-970-10, for 73 mm bb |
| chain device mount | ISCG 2005 and 2001, Hammerschmidt compatible |
| dropouts | for 12 mm through axle, replaceable derailleur eye |
| rear axle | 12 mm through axle, delivered with the frame |
| standard hub size | 12x142 mm |
| optional hub sizes | 12 x135 mm, 12x150 mm (change derailleur eye and remove/change brake spacer) |
| fork travel | 170-180 mm is recommended, max. 180 mm |
| intended usage | big mountain freeride and bike park, enduro, trail riding in extreme terrain |

Helpful Information

The HERB 180 can be converted to the HERB 160 using the 160 conversion kit, which comprises two rockers and the bearings. Simply switch the rockers - no need to change the shock.

To find specifications of discontinued models and previous versions, please have a look at www.last-bikes.com in the service category.

The information given in this document is subject to change without notice.

Geometry // HERB 180

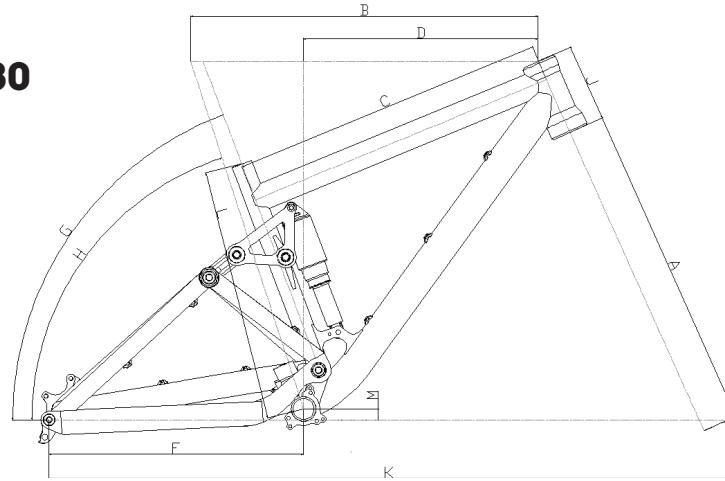

| frame size | small | medium | large |
|----------------------------------|-------------|-------------|-------------|
| example fork | RS Lyrik 12 | RS Lyrik 12 | RS Lyrik 12 |
| fork travel | 170 mm | 170 mm | 170 mm |
| A fork length + head set height | 555 + 2 mm | 555 + 2 mm | 555 + 2 mm |
| D top tube | 383 mm | 416 mm | 449 mm |
| C top tube sloped | 505 mm | 536 mm | 567 mm |
| B top tube horizontal | 569 mm | 601 mm | 637 mm |
| E chain stay length | 426 mm | 426 mm | 426 mm |
| F steering angle | 65,3 ° | 65,3 ° | 65,3 ° |
| G seat angle | 69,8 ° | 69,8 ° | 69,8 ° |
| H effective seat angle | 73,3 ° | 73,3 ° | 73,3 ° |
| J head tube length | 130 mm | 130 mm | 140 mm |
| K wheel base (40 mm fork offset) | 1126 mm | 1159 mm | 1192 mm |
| L seat tube length | 428 mm | 428 mm | 490 mm |
| M bottom bracket height | +15 mm | +15 mm | +15 mm |

Remarks

If you want to use a different fork you can easily calculate the approximate change of the steering angle. The change is about 0,5 ° - 0,4 ° towards a steeper angle per 10 mm lowered crown.

The information given in this document is subject to change without notice.