

Specification // HERB 180

version	HERB 180 (V1.1)
sizes	small, medium, large
colours	black anodized frame, red anodized linkage and hardware
material	7005 aluminum, custom butted, heat treated and ball burnished (less fatigue)
rear travel	180 mm (can be changed to 160 mm with HERB 160 rockers, use same shock length)
standard shock	Rock Shox Monarch Plus RT3 High Volume, 216 x 63,5 mm
shock hardware	8 mm bolt, top 47,8 mm width, bottom 22,2 mm width
seat post and clamp size	∅ 31,6 mm, 100 mm min. insertion, clamp ∅ 34,9 mm, not included
bearings	stainless steel sealed cartridge bearings
bearing sizes	15 x 28 x 7 mm
head tube	tapered, bottom 1,5" 1 1/8" internally and externally CNC machined
head sets	bottom - semi integrated 1,5" (55,96-56,00 mm), top 1 1/8" semi integrated (44 mm)
compatible tires	26" x 2,7"
disc mount	Internat. Standard, max. ∅ 205 mm
bb shell	BSA, 73mm, 83 mm bottom bracket with 5 mm spacers on each side
front derailleur	Shimano top swing only, for example FDM-970-10, for 73 mm bb
chain device mount	ISCG 2005 and 2001, Hammerschmidt compatible
dropouts	for 12 mm through axle, replaceable derailleur eye
rear axle	12 mm through axle, delivered with the frame
standard hub size	12x142 mm
optional hub sizes	12 x135 mm, 12x150 mm (change derailleur eye and remove/change brake spacer)
fork travel	170-180 mm is recommended, max. 180 mm
intended usage	big mountain freeride and bike park, enduro, trail riding in extreme terrain

Helpful Information

The HERB 180 can be converted to the HERB 160 using the 160 conversion kit, which comprises two rockers and the bearings. Simply switch the rockers - no need to change the shock.

To find specifications of discontinued models and previous versions, please have a look at www.last-bikes.com in the service category.

The information given in this document is subject to change without notice.

Geometry // HERB 180

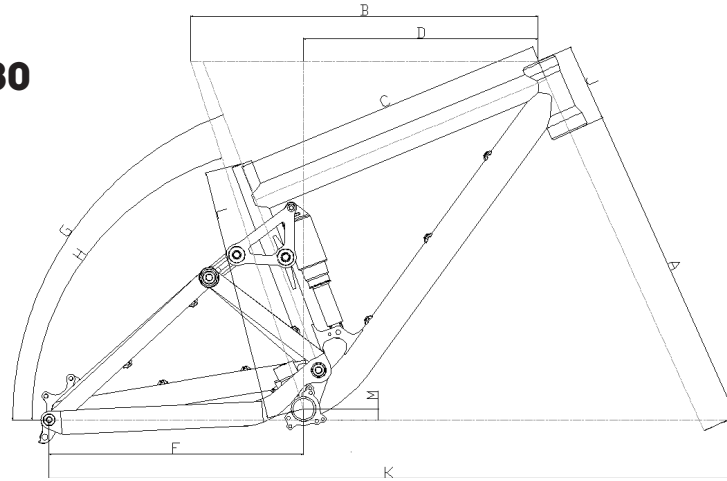

frame size	small	medium	large
example fork	RS Lyrik 12	RS Lyrik 12	RS Lyrik 12
fork travel	170 mm	170 mm	170 mm
A fork length + head set height	555 + 2 mm	555 + 2 mm	555 + 2 mm
D top tube	383 mm	416 mm	449 mm
C top tube sloped	505 mm	536 mm	567 mm
B top tube horizontal	569 mm	601 mm	637 mm
E chain stay length	426 mm	426 mm	426 mm
F steering angle	65,3 °	65,3 °	65,3 °
G seat angle	69,8 °	69,8 °	69,8 °
H effective seat angle	73,3 °	73,3 °	73,3 °
J head tube length	130 mm	130 mm	140 mm
K wheel base (40 mm fork offset)	1126 mm	1159 mm	1192 mm
L seat tube length	428 mm	428 mm	490 mm
M bottom bracket height	+15 mm	+15 mm	+15 mm

Remarks

If you want to use a different fork you can easily calculate the approximate change of the steering angle. The change is about 0,5 ° - 0,4 ° towards a steeper angle per 10 mm lowered crown.

The information given in this document is subject to change without notice.